

RL 6070, 50Hz

Electric submersible pump

Specifications

Portable electric submersible pump for dewatering of construction sites, mines, flooded areas etc. Designed for handling liquid with abrasive particles. Prot class IP68

Pump Types

RL 6072 Low head/high volume
RL 6076 High head

Electric Motor

3-phase: Squirrel cage induction motor with built-in contactor.
Insulation: Class F (+155C), IEC 85

Data		RL 6072	RL 6076
Rated Output	kW	11.8	11.8
Rated Current A	230v	40	40
	400v	23	23
	500v	18	18
Shaft speed	rpm	2900	2900

Other voltage upon request

Motor Protection

Thermal switch in each winding (+135 degree C)

Cable

Oil and wear resistant rubber cable type HO7RN-F
230v, 20m 4x10mm²
400v, 20m 4x4mm²

Shaft Seal

Double mechanical seals with oil compartment.
Primary seal: Tungsten carbide against ceramic.
Secondary seal: Carbon against ceramic.
Available in a complete seal pack or as separate items.

Bearings

Upper: Ball bearings with C3 clearance
Lower: Dual ball bearings with C3 clearance

Materials

Castings: Aluminium
Outer-casing: Galvanized steel
Shaft: Stainless steel
Fasteners: Stainless steel
Impeller: Cr-alloyed white cast iron, 55Rc
Wear parts: Natural rubber

Discharge connection

6" std for RL 6072, 4" std for RL 6076, for hose, BSP or NPT

Accessories

Built-in Y/D starter
Zinc anodes
NVB automatic level control
Epoxy coating
Float switch

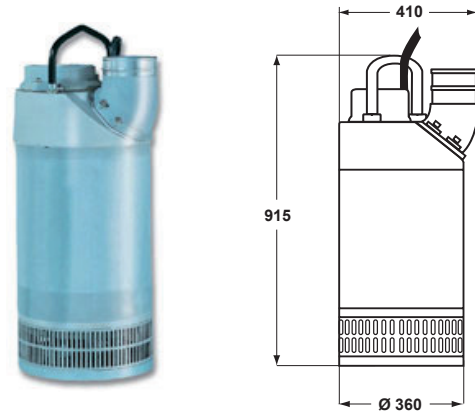

Weight: 95 kg

Dimensions (mm).

Power (kW)

According to ISO 9906 - ANNEX A

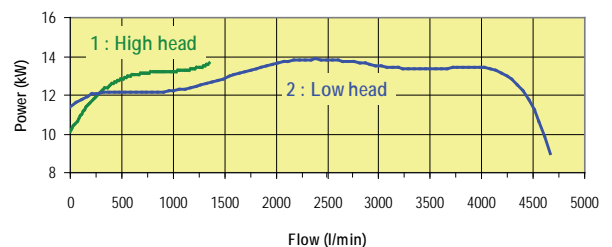

Flow Chart

According to ISO 9906 - ANNEX A

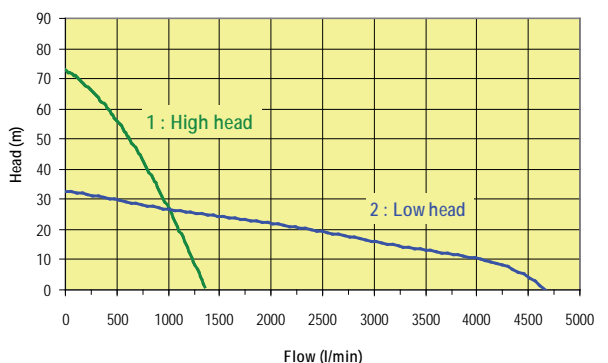

Features

Robust design
User friendly
Wear resistant wet end in CR-alloy steel and natural rubber
Adjustable wear parts
Complete seal pack for easy and fast service
Built-in contactor for DOL start
Easy installation

Designed for:

Heavy duty pumping of abrasive liquids
Max submersible depth of 20m
Max temperature of liquid +40C
Max density of liquid, 1.100kg/m³
pH of the liquid between 5-8
For special applications contact Weda pump

WEDA PUMP
World leader in professional submersible drainage pumps

Delta Pompen B.V. – Lübeckstraat 12 – 7575 EE – Oldenzaal – The Netherlands

Tel.: +31 (0)541-571667 – Fax.: +31 (0)541-571669 – info@wedapump.com – http://www.wedapump.com

RL 6070, 60Hz

Electric submersible pump

Specifications

Portable electric submersible pump for dewatering of construction sites, mines, flooded areas etc. Designed for handling liquid with abrasive particles. Prot class IP68

Pump Types

RL 6073 Low head/high volume
RL 6077 High head

Electric Motor

3-phase: Squirrel cage induction motor with built-in contactor.
Insulation: Class F (+311F), IEC 85

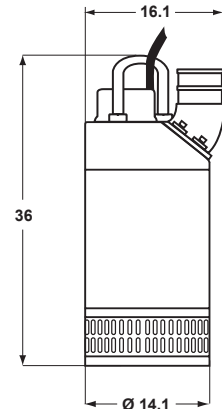

Data		RL 6073	RL 6077
Rated Output	hp	14	18
Rated Current A	460v	20.6	25.3
Shaft speed	rpm	3550	3550

Other voltage upon request

Motor Protection

Thermal switch in each winding (+266 degree F)

Cable

Oil and wear resistant rubber cable
65ft 4xAWG 10

Shaft Seal

Double mechanical seals with oil compartment.
Primary seal: Tungsten carbide against ceramic.
Secondary seal: Carbon against ceramic.
Available in a complete seal pack or as separate items.

Bearings

Upper: Ball bearings with C3 clearance
Lower: Dual ball bearings with C3 clearance

Materials

Castings: Aluminium
Outer-casing: Galvanized steel
Shaft: Stainless steel
Fasteners: Stainless steel
Impeller: Cr-alloyed white cast iron, 55Rc
Wear parts: Natural rubber

Discharge connection

6" NPT std for RL 6073, 4" NPT std for RL 6077,
opt hose or BSP

Accessories

Built-in Y/D starter
Zinc anodes
NVB automatic level control (RL 6073 DOL only)
Epoxy coating
Float switch



Weight: 210 lbs

Dimensions (in).

Flow Chart

According to ISO 9906 - ANNEX A

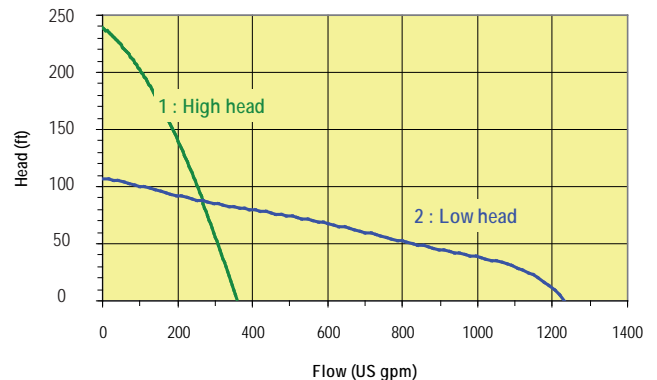

Features

- Robust design
- User friendly
- Wear resistant wet end in CR-alloy steel and natural rubber
- Adjustable wear parts
- Complete seal pack for easy and fast service
- Built-in contactor for DOL start
- Easy installation

Designed for:

- Heavy duty pumping of abrasive liquids
- Max submersible depth of 66ft
- Max temperature of liquid +104F
- Max density of liquid, 68lbs/ft³
- pH of the liquid between 5-8
- For special applications contact Weda pump

