

WEDA PUMP

World leader in professional submersible drainage pumps

INSTRUCTIONS & SPAREPARTS CATALOGUE RL 2010



RL2010 – IS – 10587 – 1 – ENG – GSNL

SAFETY INSTRUCTIONS

- **MACHINES SUBMITTED** : Powered with : Electric, Pneumatic, Petrol or Diesel engine.

- **SYMBOLS** : The words **WARNING** and **CAUTION** used in safety instructions, have the following meanings :
WARNING indicates hazards or hazardous procedures which could result in serious injury or death , if the **WARNING** is not observed.
CAUTION indicates hazards or hazardous procedures which could result in injury or damage to equipment if the **WARNING** is not observed.

- **IMPORTANT RULES FOR YOUR SAFETY** :



WARNING

The machine must not be modified without prior consent of the manufacturer. Use only original parts. If modifications are made without prior consent of the manufacturer there is a risk of serious injury to the personal.

- These safety recommendations have been compiled from international safety standards. Local regulations must also be checked and observed. Before using the machine, read carefully these instructions and keep them in a safe place.
- Make sure that the signs about using, safety, and maintenance are always legible.
- The use of the machine is restricted to the applications specified in the product literature.
- Always change damaged parts immediately. Change wear parts in due time.

- **SAFETY EQUIPMENT** :



WARNING

The admissible sound level of 85 dB (A), can be exceeded because of the machine and/or the application. Long time exposure to loud noise without ear protectors can cause permanent damage to hearing. Long time exposure to vibrations can damage the hands, fingers and wrists. Do not use the machine if you are experiencing discomfort, cramp or pain. Consult a doctor before working again with the machine.

- Always use approved safety equipment. The following safety equipment applies to operators and other personnel in the immediate vicinity of the working zone.
- Safety helmet.
- Ear protectors.
- Dust mask in dusty environments.
- Protective gloves.
- Protective shoes.
- Goggles.

To avoid the risk of clothes being caught in the machine, avoid wearing loose-lifting clothes. If you have long hair, cover it with a hair net.

- **WORKING AREA** :



WARNING

Do not use the machine in explosive environments. Do not operate a machine powered by a petrol or diesel engine in poorly ventilated spaces. These types of engines produce toxic gases which can cause serious health troubles.

- POWER SUPPLY :



WARNING

Make sure that the power supply equipment complies with the relevant safety requirements of the local and the international standards.

- **Electric machine** : It must be ensured that the machine is connected to the voltage and the frequency specified on the name plate. The power supply cable has to be properly sized. Check that the cable and the plug of the machine are not damaged. Never switch off the machine by pulling the plug from its socket. Use the machine switch. Keep the cable out of the moving parts of the machine.

- **Pneumatic machine** : Check that the compressed-air hose and the hose coupling are not damaged. Never attempt to loosen a compressed-air hose which is pressurized. First switch off the air at the compressor and then leave the machine running itself to discharge the hose after some seconds.

- **Machine powered by petrol or diesel engine** : Petrol has an extremely low flash-point and can be explosive in certain situations. Keep away from all hot or spark-generating objects, do not smoke, when handling fuel. Wait until the machine has cooled before filling the tank. Avoid spilling petrol or diesel on the ground.

- STARTING THE MACHINE :



CAUTION

Before starting make yourself familiar with the machine and make sure that the machine does not show any obvious faults. Then start the machine according the instruction and spare parts catalogue.

- OPERATION :



CAUTION

Use the machine only for the purpose for which it is intended. Make sure you know how to stop the machine quickly in the event of an emergency situation. Do not touch rotating parts during operation.

- MAINTENANCE :



CAUTION

Maintenance work must only be carried out by skilled personnel. Keep unauthorized persons away from the machine. Do not carry out maintenance work while the machine is moving or the engine is running. Never use a machine which is damaged.

- BE ALERT :



CAUTION

Always concentrate on what you are doing. Use common sense. Never operate the machine if you are tired or under the influence of drugs alcohol or other substances which can affect your vision, reaction, ability or judgement.

GENERAL

The RL submersible drainage pumps are designed for pumping lightly contaminated water .

DESIGN

The heavy duty light weight aluminium construction includes a cooling jacket ensuring adequate motor cooling at all times .

The pumps are in 'plug and pumping design' , with built-in full overheat motor protection .

The versions with level float switch allow automatic operation .

The unique cartridge type seal package can be easily replaced on site with only minimum downtime .

For demanding applications as in construction works and mining , the impellers are made for wear resistant Hi-Chrome iron and all other components are rubber lined .

The impeller clearance is easily adjustable to compensate for wear .

TECHNICAL DATA

	RL2010
Pump :	
Discharge mm - (in)	50 - (2")
Suitable for media with pH	5 - 8
Maximum water temperature	40°C
Maximum submersible depth m - (ft)	20 - (67)
Maximum solids size mm - (in)	Ø4 - (0.16)
Weight (excluding cable) kg - (lb)	12.50 - (27.50)
Strainer	Rectangular holes 4 x 27 mm
Speed rpm 50Hz (60Hz)	2980 - (3550)
Stator insulation class	F (155°C)

Voltages V	Phases	Frequency Hz	Rated current A	Rated electrical power (kW)
110	1	50	12.8	1.4
220-240	1	50	6.1	1.4
380-415	3	50	2.3	1.4
110	1	60	13	1.4
220	1	60	6.2	1.4
440	3	60	2.2	1.4

Other voltages upon request

IMPORTANT

The above information is a general description only, is not guaranteed and contains no warranties of any kind

Power cables (50Hz)

15 meters 3x2.5 mm² for 110 V ' 1 phase .
20 meters 3x1.5 mm² for 220-240 V ' 1 phase .
20 meters 4x1.5 mm² for other voltages.
All cables polychloroprene type HO7RN-F .

Power cables (60Hz) only for CSA approved types

15 meters SOW 3xAWG14 for 110V - 1 phase
20 meters SOW 3xAWG16 for 220V-240V - 1 phase
20 meters SOW 4xAWG16 for 440V-460V - 3 phases

Hydraulic characteristics

50Hz

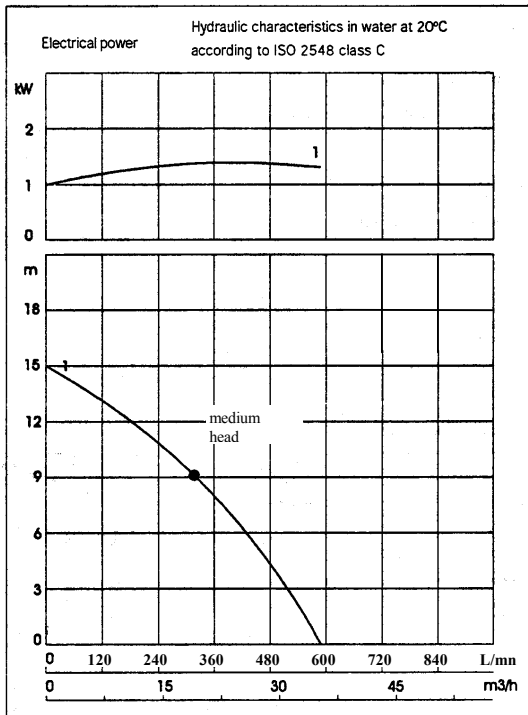

60Hz

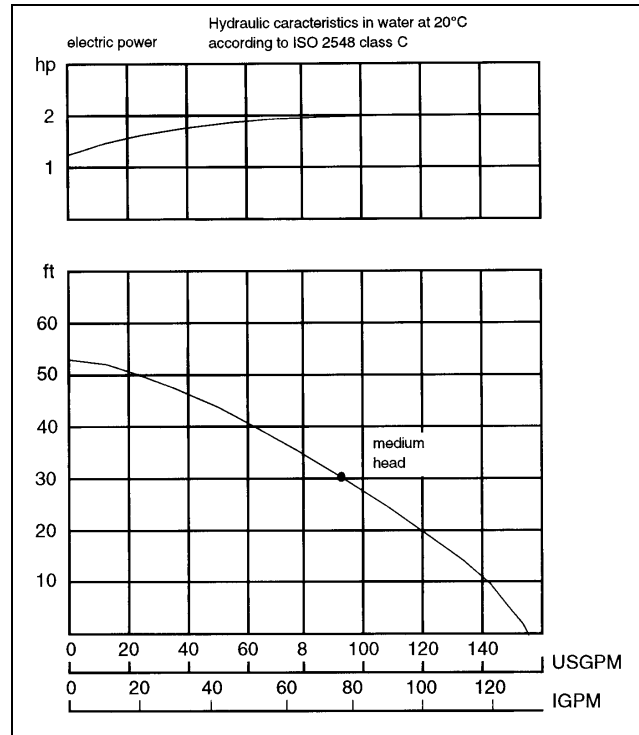

Dimensions

Dimensions in mm
(Dimensions in inch)

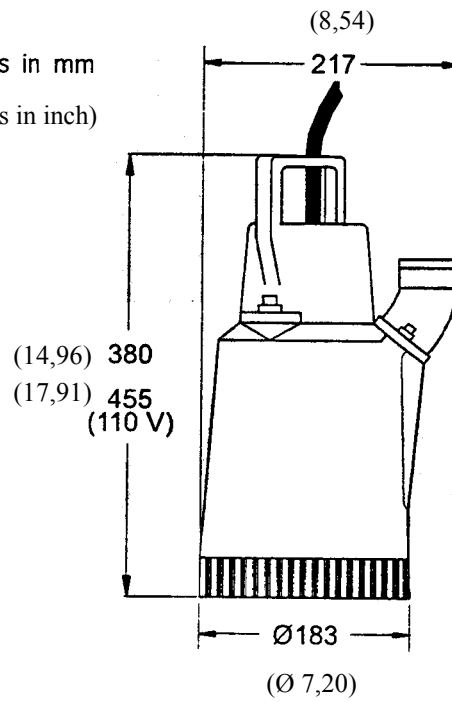

DISCHARGES AVAILABLE

2" Hose standard P/N W214251 with 1 clamp
2" BSP - thread P/N W214280
2" NPT - thread P/N W214489

Note :the discharges have to be ordered separately .

PUMPS PART NUMBERS

Power supply

110V - 1 - 50Hz
220/240V - 1 - 50Hz
380/415V - 3 - 50Hz
110V - 1 - 60Hz
220V - 1 - 60Hz
440V - 3 - 60Hz

Part Number (1)

RL2014B4111
RL2014B4231
RL2014B3562
RL2015B4111
RL2015B4331
RL2015B3562

(1) The letter B means basic construction, but the following main options are also available , according to the pump type :

C : High style strainer , stainless steel .
H : Canada Standard Association certified.
N : Level control (float switch).
Z : Zinc anodes.
P : N + Z options.

INTALLATION



The pump must not be used in an explosive / inflammable environment or used to pump inflammable liquids !

- Route the cables so that connectors do not lie in the water. Consider the risk of electrical accident.



Never lift the pump by its power cable !

- Connect a discharge hose of approved pressure class.
- The discharge hose may be thrown off when the pump starts.
- No one must be allowed in the water, e.g. swimming pools, when the pump is running.
- Check that the pump is standing steady, or suspend it from its lifting ring.
- **Check the direction of rotation, pointed by the starting kick arrow printed in the outer casing (anti-clockwise)**

The pump will start instantaneously when it is connected to the power supply.

The pump may kick violently when it starts.

In case of wrong direction of rotation two phases should be inverted from the supply (three phases voltage only).



ELECTRICAL CONNECTION

Check that the details on the pump data plate match with the mains voltage and frequency.



**The electrical installation must be carried out by a qualified electrician !
Local installation regulations must be followed !**

Make sure that the pump is properly earthed. The earth conductor must be slightly longer than the phase conductors. If the motor power cable is accidentally pulled off, the earth conductor must be the last conductor to be removed from the terminals.

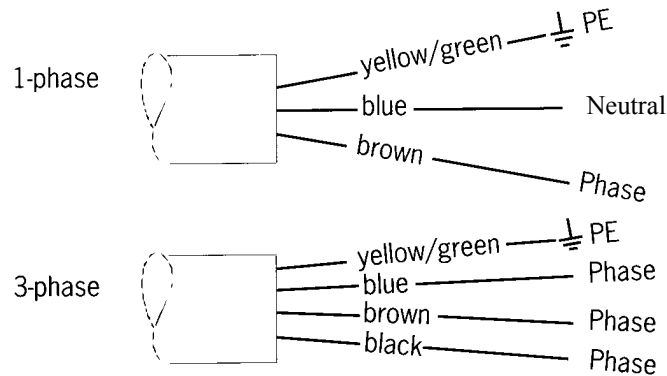

Pumps must be connected to an approved motor protection.

BUILT-IN MOTOR PROTECTION



Check that the pump is disconnected from the power supply before starting any work !

The pump's built-in motor protection switches off the contactor automatically if the motor overheats. Then, the fault must be identified and corrected. After cooling to normal working temperature, the motor protection switches on the contactor and the pump starts again.

TROUBLE SHOOTING

Fault location	Cause	Action
Pump will not start.	<ol style="list-style-type: none"> 1. Fuses blown 2. Broken cable 3. Power failure 4. Jammed impeller 5. Faulty contactor 6. Stator winding burnt-out 7. Incorrect phase sequence (3 phases) 	<ol style="list-style-type: none"> 1. Replace fuses 2. Service 3. – 4. Clean bottom of pump 5. Service 6. Service 7. Change 2 phases in plug
Pump starts, but stops again.	<ol style="list-style-type: none"> 1. Pump runs backwards (3 phases) 2. Pump connected to wrong voltage 3. Phase interruption 4. Strainer blocked 5. Insufficient water level 6. Voltage too low when using an extra cable 7. Water too hot 	<ol style="list-style-type: none"> 1. Change 2 phases in plug 2. Select the right voltage 3. Check fuses 4. Clean strainer 5. Stop the pump 6. Increase the extra cable section 7. Switch off power
Pump works, but delivers too small water volume .	<ol style="list-style-type: none"> 1. Impeller worn 2. Pump runs backwards (3 phases) 3. Hose dimensions unsuitable 4. Insufficient discharge head 	<ol style="list-style-type: none"> 1. Adjust pump/replace impeller 2. Change 2 phases in plug 3. Change to suitable hose 4. Select a bigger pump

MAINTENANCE

Pump performance

To keep the pump performance, the gaps must be as small as possible. The gap between the impeller and the wear plate is adjustable with trim washers. The gap between the impeller and the diffuser is adjusted by alternatively tightening the nuts fixing the diffuser. After adjustment the impeller must be capable of rotation by hand.



Worn impeller can have very sharp edges . Wear safety gloves !

Bearings

The RL2010 bearings are greased for life with high temperature grease and anti-corrosion additive .

No inspection required between service intervals. Recommended lubricant : TRIBOTEC OKS400/00 : Universal Heavy Duty grease.

Grease each 4-6 months the shaft seal through the grease nipple situated on the pump body (Fig 1) .

When servicing replace systematically following parts :

Items : 61 and 63 . See spare part pages .

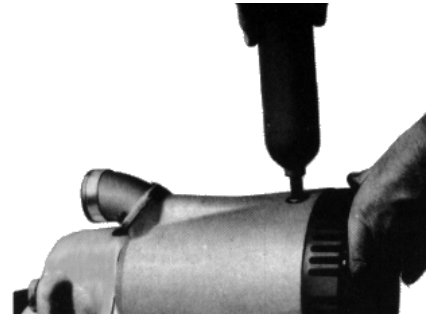

Fig 1

MAINTENANCE KITS

Part number	Description	Parts included
W214879	Gasket set	Parts 19 , 24 , 30 , 48 , 49 , 55 , 62 , 64 .
W214880	Wear part set RL2014 - 50Hz	Parts 65 , 67 , 68 , 70 .
W214881	Wear part set RL2015 - 60Hz	Parts 65 , 67 , 68 , 70 .

Note : Refer to spare part pages .

ACCESSORIES

- FLOOR LEVEL BAND P/N : W214800 (pos 72)
- FLOAT SWITCH P/N : W214842

RL2010 series pump can be equipped with a float switch.

Switching on an off is regulated by the length of the float switch cable. See fig. 5,6.

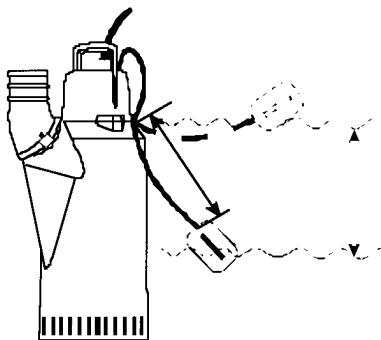

Fig. 6

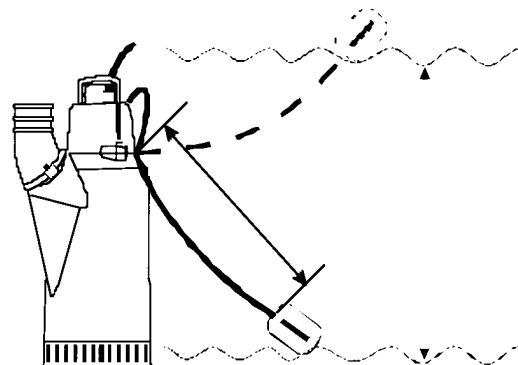
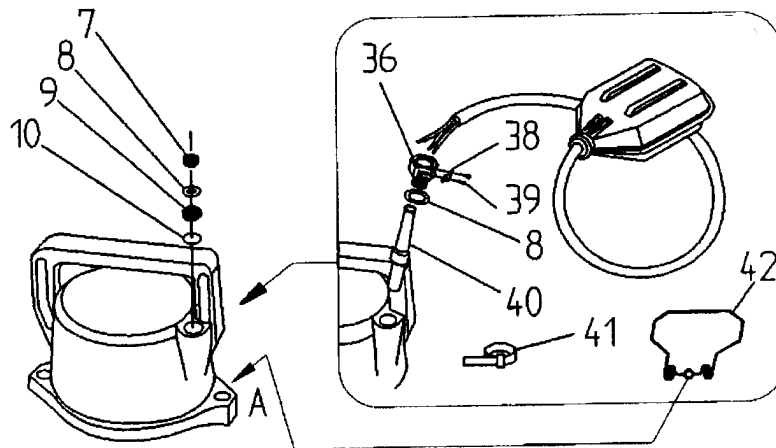

Fig. 5

ASSEMBLING OF FLOAT-SWITCH



1. Dismantle pos. 7, 8, 9 and 10, use a hexagon key size 8.
2. Put pos. 36 and 8 on the cable.
3. Place pos. 40 approx. 300 mm on the cable, use soap water.
4. Assemble float-switch on the cover, use spanner size 19.
5. Assemble pos. 38 and 39, use screw driver.
6. Place pos. 41 on the cable .With this clamp (pos. 41) the cable can be shorten.
7. Dismantle M6 nut at A, place pos. 42 and put the nut back, use spanner size 10.Pos. 42 is a holder for the float at transport.

ZINC ANODES P/N W209289

When pumping salt water (which is highly aggressive towards aluminium) , the pump should be protected with zinc anodes.

INSTALLATION

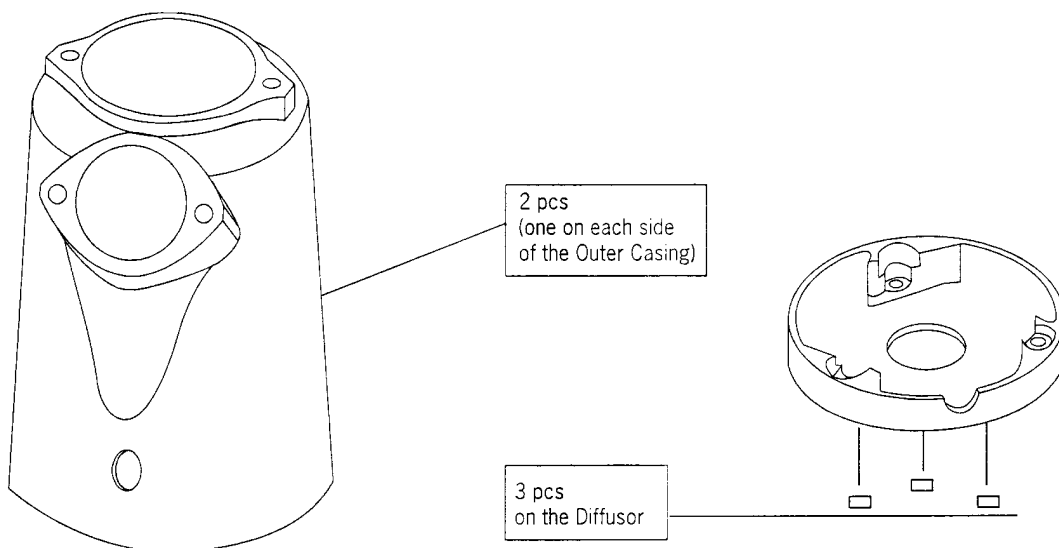

WIRING DIAGRAM

WIRING DIAGRAM 1 PHASE

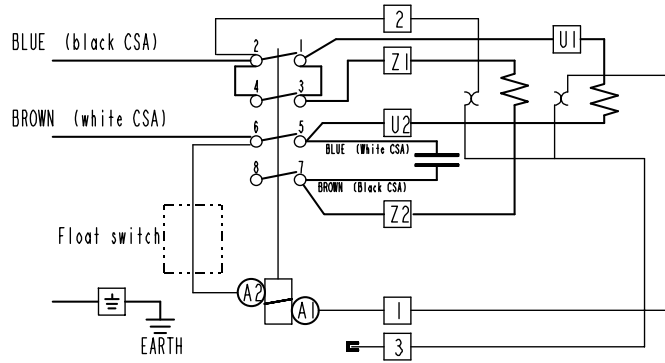

WIRING DIAGRAM ⊗ CONNECTION 3 PHASES

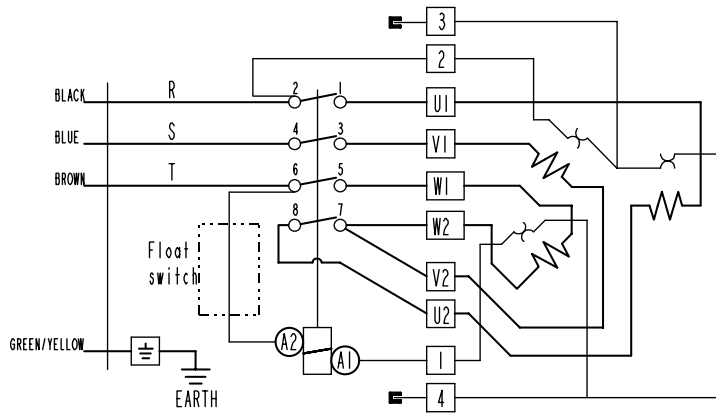

WIRING DIAGRAM ↗ CONNECTION 3 PHASES

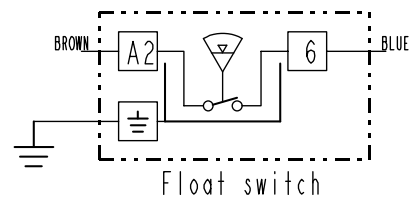
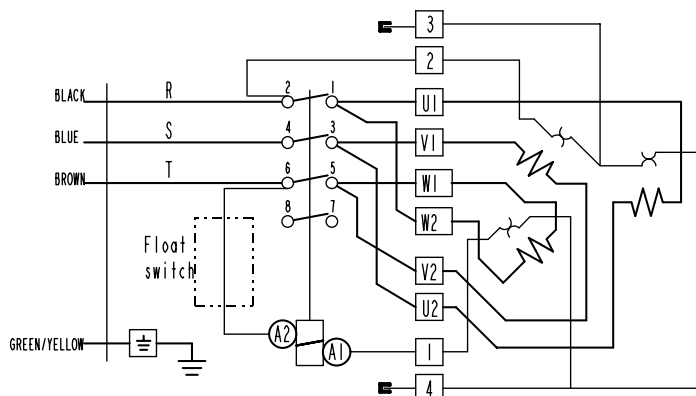

WEDA PUMP

World leader in professional submersible drainage pumps

Delta Pompen B.V.

P.O. Box 310

7570 AH Oldenzaal

THE NETHERLANDS

Tel. : +31 (0)541 571667

Fax.: +31 (0)541 571669

E-mail: info@wedapump.com

Internet: <http://www.wedapump.com>

Lübeckstraat 12

7575 EE Oldenzaal

SERVICE AND GUARANTEE.

WEDAPUMP.COM is represented worldwide by a well-established service organization. Contact your local WEDAPUMP sales office if you require more information about servicing. Or left mentioned address.