

RL 4060, 50Hz

Electric submersible pump

Specifications

Portable electric submersible pump for dewatering of construction sites, mines, flooded areas etc. Designed for handling liquid with abrasive particles. Prot class IP68

Pump Types

RL 4064 Medium head
RL 4066 High head

Electric Motor

3-phase: Squirrel cage induction motor with built-in contactor.
Insulation: Class F (+155C), IEC 85

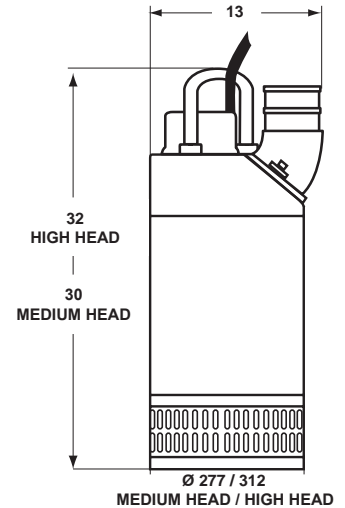

Data		RL 4064	RL 4066
Rated Output	kW	7.5	7.5
Rated Current A	230v	31	31
	400v	16	16
	500v	13	13
Shaft speed	rpm	2900	2900

Other voltage upon request

Weight RL 4064 55 kg Dimensions (mm).
RL 4066 63 kg

Power (kW)

According to ISO 9906 - ANNEX A

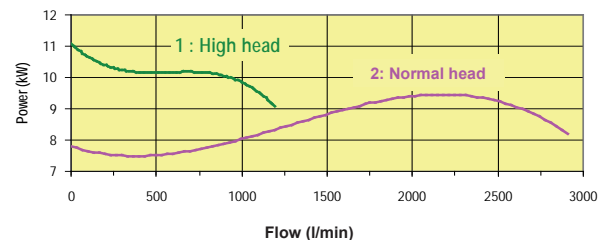

Motor Protection

Thermal switch in each winding (+135 degree C)

Cable

Oil and wear resistant rubber cable type HO7RN-F
230v, 20m 4x4mm²
400v, 20m 4x2.5mm²

Shaft Seal

Primary seal: Silicon carbide against silicon carbide.
Secondary seal: Carbon against ceramic
Available in a complete seal pack or as separate items.

Bearings

Single-row ball bearing with C3 clearance

Materials

Castings: Aluminium
Outer-casing: Aluminium
Shaft: Stainless steel
Fasteners: Stainless steel
Impeller: Cr-alloyed white cast iron, 55Rc
Wear parts: Natural rubber

Discharge connection

4" std for RL 4064, 3" std for RL 4066, for hose, BSP or NPT

Accessories

Float switch
Zinc anodes
NVB automatic level control
Epoxy coating

Flow Chart

According to ISO 9906 - ANNEX A

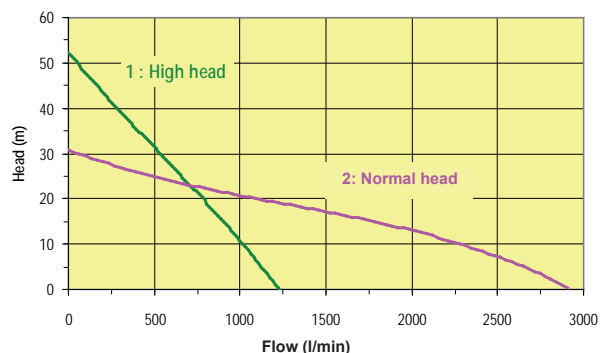

Features

Robust design
Lightweight and user friendly
Wear resistant wet end in CR-alloy steel and natural rubber
Adjustable wear parts
Complete seal pack for easy and fast service
Built-in contactor for DOL start
Easy installation

Designed for:

Heavy duty pumping of abrasive liquids
Max submersible depth of 20m
Max temperature of liquid +40C
Max density of liquid, 1.100kg/m³
pH of the liquid between 5-8
For special applications contact Weda pump

WEDA PUMP
World leader in professional submersible drainage pumps